

# MBE 9A8

8 Zylinder COP 1-5-4-8-6-3-7-2

2 Lambda

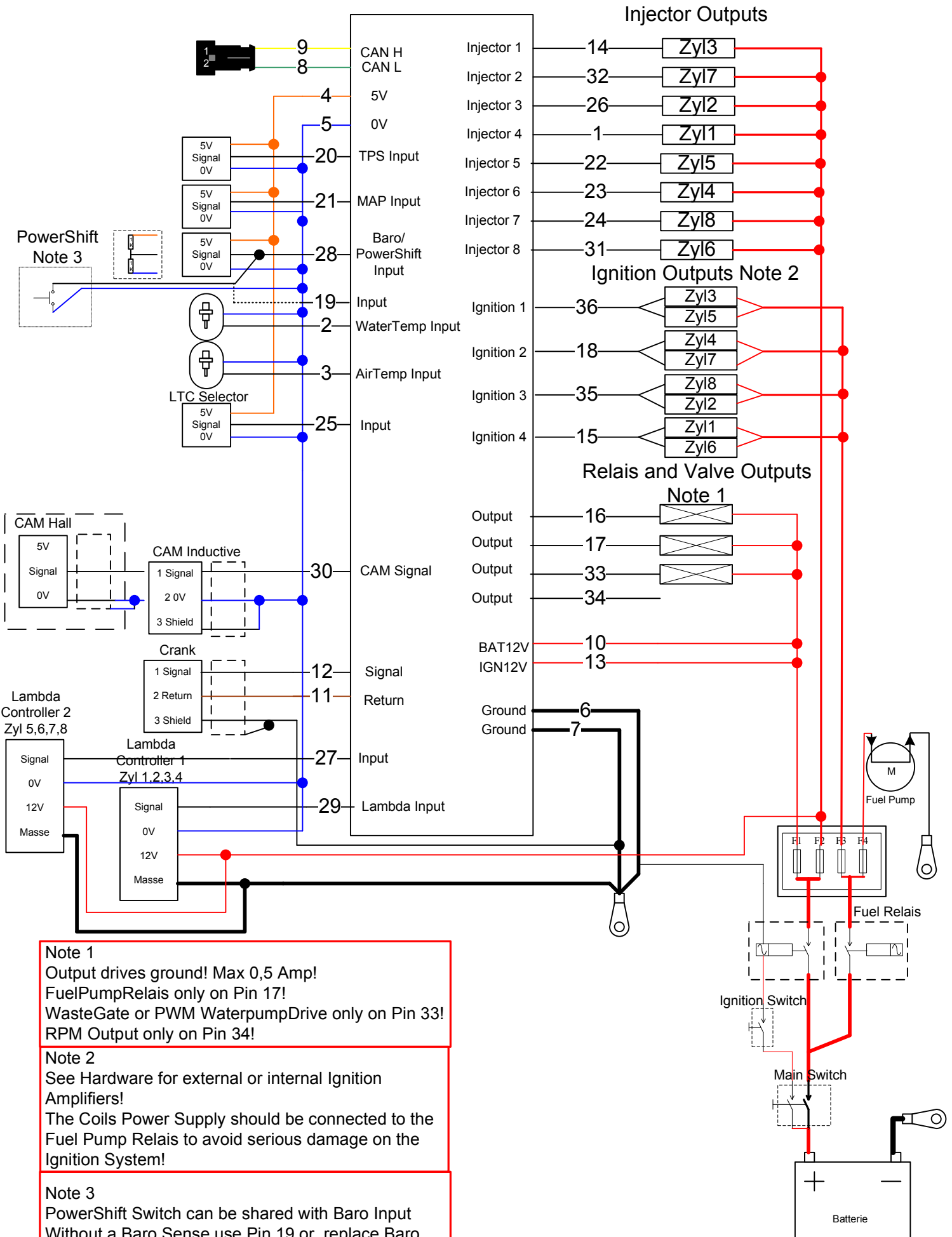

**Note 1**  
 Output drives ground! Max 0,5 Amp!  
 FuelPumpRelais only on Pin 17!  
 WasteGate or PWM WaterpumpDrive only on Pin 33!  
 RPM Output only on Pin 34!

**Note 2**  
 See Hardware for external or internal Ignition Amplifiers!  
 The Coils Power Supply should be connected to the Fuel Pump Relais to avoid serious damage on the Ignition System!

**Note 3**  
 PowerShift Switch can be shared with Baro Input  
 Without a Baro Sense use Pin 19 or replace Baro Sense with Resistors!